

# 1986-1987 BUICK TURBO REGAL Reproduction Spark Plug Wire Set (6)

This reproduction set of six (6) spark plug wires match up very close to the original 1986-1987 Turbo Regal wires. The color is also very close to the original gray. The coil terminal boots and the spark plug boots are also correct. The coil pack terminal ends are a match to the originals with one improvement. The inside is ribbed for a tighter fit. The spark plug boots are similar in appearance. These spark plug wires are **"MADE IN THE USA"**.

To ensure an exact fit to the original factory format, you need to have the factory brackets that secure the six (6) plug wires. On the passenger side, the one bracket is attached to a small metal bracket on the front of the valve cover.

On the driver's side, you have two brackets - one in the back of the black plastic harness loop and one inward off the EGR solenoid.

All three (3) mounting brackets require the standard plastic three (3) wire divider. It is critical to make sure none of the wires cross over the edges on top of the plenum. The sharp edges of the plenum can eventually cut through the plug wires and cause a misfire.

At the same time it pays to invest in proper fitting wires to prevent the chance of any universal set of wires from coming in contact with the headers.

## ILLUSTRATION OF THE DRIVER'S SIDE OF THE ENGINE

Note: Spark plug wire lengths are from the very end of the tip on the spark plug to the 90 degree angle at the coil. Measurements were taken from an original set of spark plug wires and are approximate measurements for placement only. The illustrations show the basic format and how the spark plug wires were run from the factory. Noted are the approximate lengths of each spark plug wire.

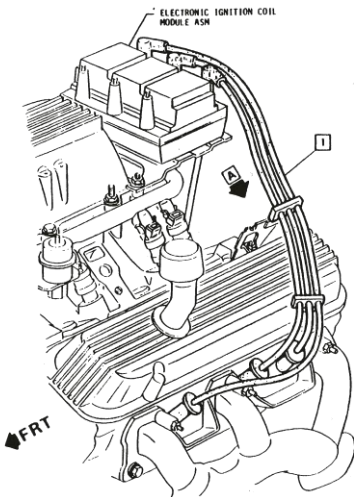

Spark plug wire lengths are from the rear going forward:

#5 Spark plug wire is approximately 23"

#3 Spark plug wire is approximately 21-1/2"

# 1 Spark plug wire is approximately 29-1/2"

## ILLUSTRATION OF THE PASSENGER SIDE OF THE ENGINE

Note: Spark plug wire lengths are from the very end of the tip on the spark plug to the 90 degree angle at the coil. Measurements were taken from an original set of spark plug wires and are approximate measurements for placement only.

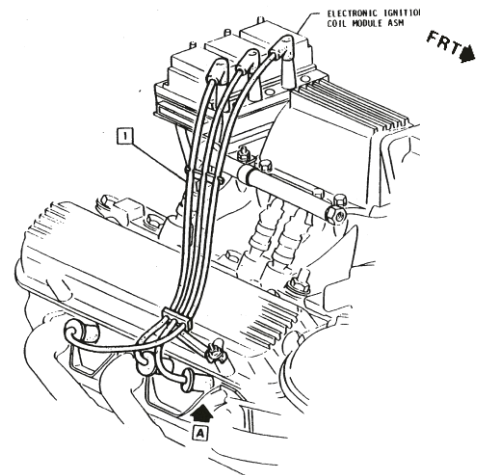

Spark plug wire lengths are from the rear going forward:

#6 Spark plug wire is approximately 26-1/2"

#4 Spark plug wire is approximately 22"

# 2 Spark plug wire is approximately 23"

Note: If you are missing any of the factory spark plug wire holders, we have them [HERE](#). This will allow you to secure the spark plug wires like they were originally.